

# OCS8487B

## Combined oven with steamer



Installation: Built-in

Range: Craft

Medium

Main colour: Colour of dark grey brushed stainless steel

Product dimensions (HxWxD): 45,5 × 59,7 × 54,7 cm

5 Air Flow™ system, Pure steam system, Oven volume - 50 L, AquaClean, 1 level telescopic fully extendable, Sous-vide, AutoRoast, Defrost, Eco

A+



5 Air Flow™ system



Pure steam system



Oven volume - 50 L



AquaClean



1 level telescopic fully extendable



Sous-vide



AutoRoast



Defrost



Eco



### Construction & Performance

- SilverMatte
- Maximum oven temperature: 230 °C
- Meat Probe
- MultiSteam 360°

### Use & flexibility

- Interior lights (Illumination): Both sides
- Water container: 1,3 l
- Volume net (liter): 50 l
- OpenView
- Fully extendable guides
- Fully extendable telescopic guides on one level with stop function
- 1 Premium grill rack
- 1 Full width steam tray non-perforated
- 1 Full width steam tray perforated
- 1 Shallow tray

### Interaction & Control

- Knob shape: Ergonomic knobs
- TFT display

### Programs

- Lower heater BIO
- Upper heater
- Lower and upper heater
- Small infra heater
- Large infra heater
- Large infra heater with ventilaton
- Circular heater
- Eco function
- Lower heater and fan
- Lower heater with fan BIO
- Strong steam
- Medium steam
- Low steam
- Steam baking
- Direct steam injection
- Defrost
- WarmPlate
- FastPreheat

### Standard accessories

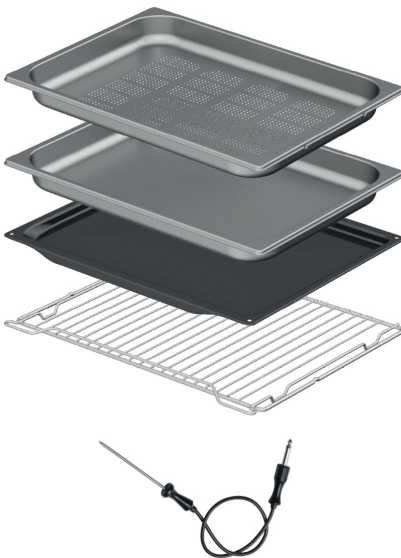

FORS AG  
Schafftenholzweg 8  
2557 Studen BE  
Tel. 032 374 26 26, info@fors.ch

  
Inspired by Scandinavia

- STEPBake
  - AutoRoast
- 

#### **Design & integration**

- Door material: Glass
  - Main colour: Colour of dark grey brushed stainless steel
  - Adjustable feet: 4
  - Niche dimensions (HxWxD): 45 × 56 × 55 cm
- 

#### **Safety & Maintenance**

- Dynamic oven cooling plus - DC+
  - Door glass: Triple glazed oven door with double heat deflector (UltraCoolDoor)
  - SoftOpen and GentleClose door hinge
  - Removable flat oven inner door glass surface
  - AquaClean function
  - Direct steam injection
  - Descaling
- 

#### **Technical data**

- Energy consumption in standby mode: 1 W
  - Energy class: A+
  - Oven consumption (conventional operation): 0,82 kWh
  - Oven consumption (venting operation): 0,62 kWh
  - Energy consumption conventional: 0,82 kWh
  - Energy consumption forced air: 0,62 kWh
  - Connected load: 2900 W
  - Voltage (V): 220-240 V
  - Nominal current: 16 amp
  - Frequency: 50 Hz
- 

#### **Dimensions**

- Product dimensions (HxWxD): 45,5 × 59,7 × 54,7 cm
  - Length electrical cord: 1,5 m
  - Net weight: 43,5 kg
- 

#### **Logistic information**

- Dimensions of packed product (HxWxD): 55 × 66 × 70 cm
  - Gross weight: 48,2 kg
  - Product code: 736347
  - EAN code: 3838782425042
-

