



DC7784HP.W

Drying cabinet

General description

DC7784HP.W
Construction type: Heat pump
Installation: Freestanding
Main colour: White

Construction & Performance

- Reinforced and sound insulated door
- Door guide for perfect alignment
- Dewatering capacity: 22 g/min
- Total drying length: 16 m
- Drying capacity: 5 kg
- Airflow: 945 m³/h
- Shortest program time (min): 75 min

Interaction & Control

- Program selector and option keys
- Memorizing intelligent system

Design & integration

- Reversible door hanger
- Flush installation height with tower of Washing machine, Tumble dryer and Hidden helper
- Possible to install in cabinet
- Possible to wall mount
- Condensate container position: Below
- Condensate drain way: Container and drain
- Motor location: Below drying compartment

Safety & Maintenance

- Door switch

Technical data

- Noise level: 70 dB(A)re 1 pW
- Plug type: Euro
- Number of phases: 1
- Frequency: 50 Hz
- Net weight: 93 kg
- ISO 14001

Dimensions

- Product dimensions (HxWxD): 185,4 × 59,5 × 66,3 cm
- Depth with door open: 1237 mm
- Length electrical cord: 2,3 m

Logistic information

- Dimensions of packed product (HxWxD): 190 × 65 × 73 cm
- Gross weight: 99 kg
- Product code: 675927
- EAN code: 3838782070167

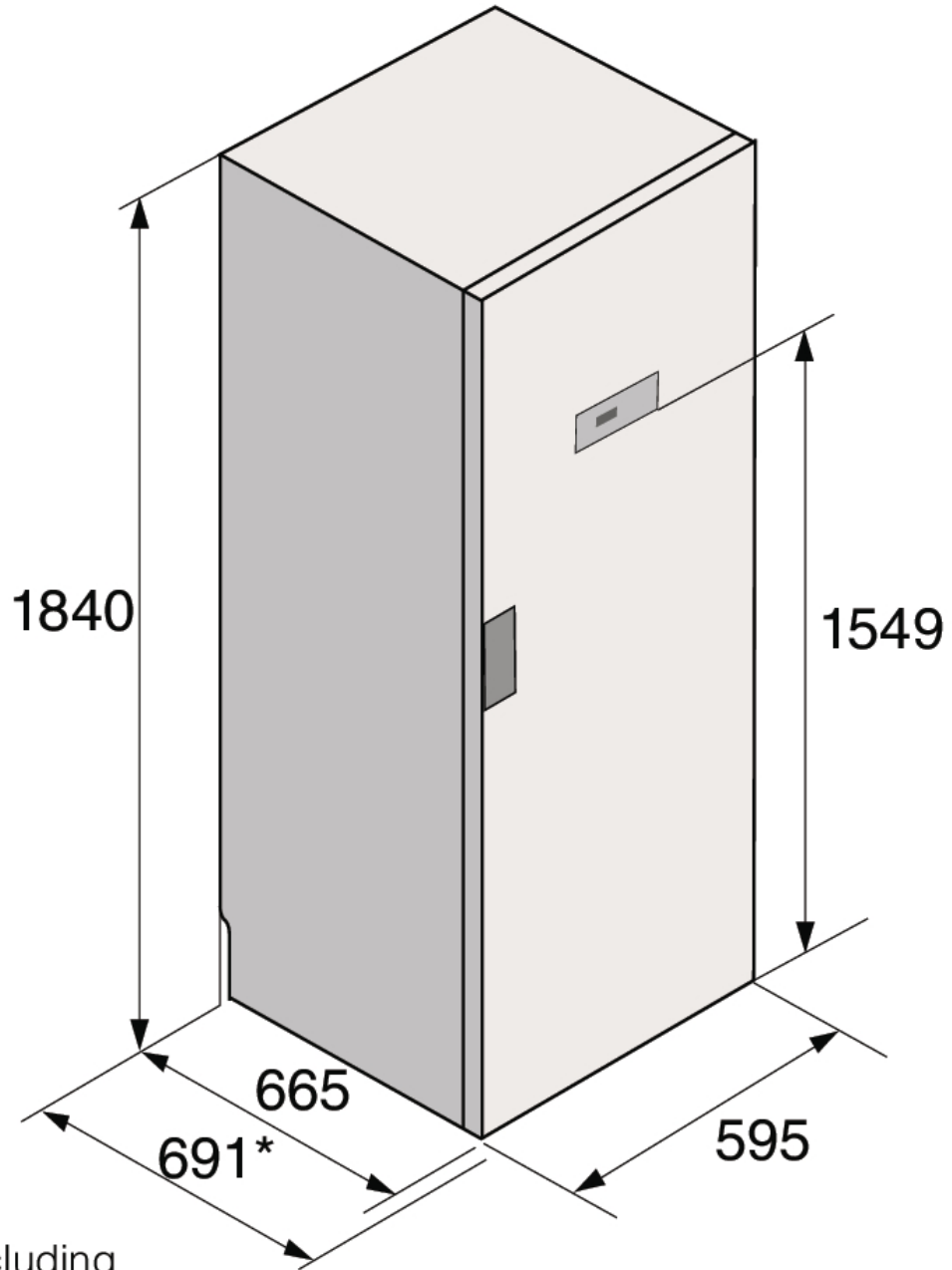

* Including handle